



Model Train[™]
TECHNOLOGY

NANO PRECISION DETECTOR 2[™]

Through-Hole & Slide-under

1mm precision up to 150mm

OPERATIONS MANUAL

Version 2.0b

Works with N, HO and O Scale

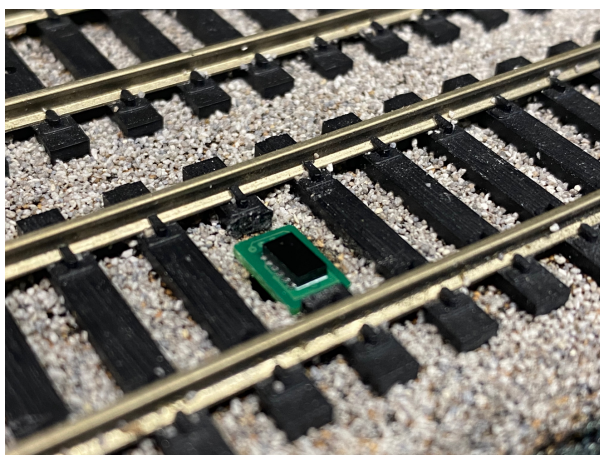

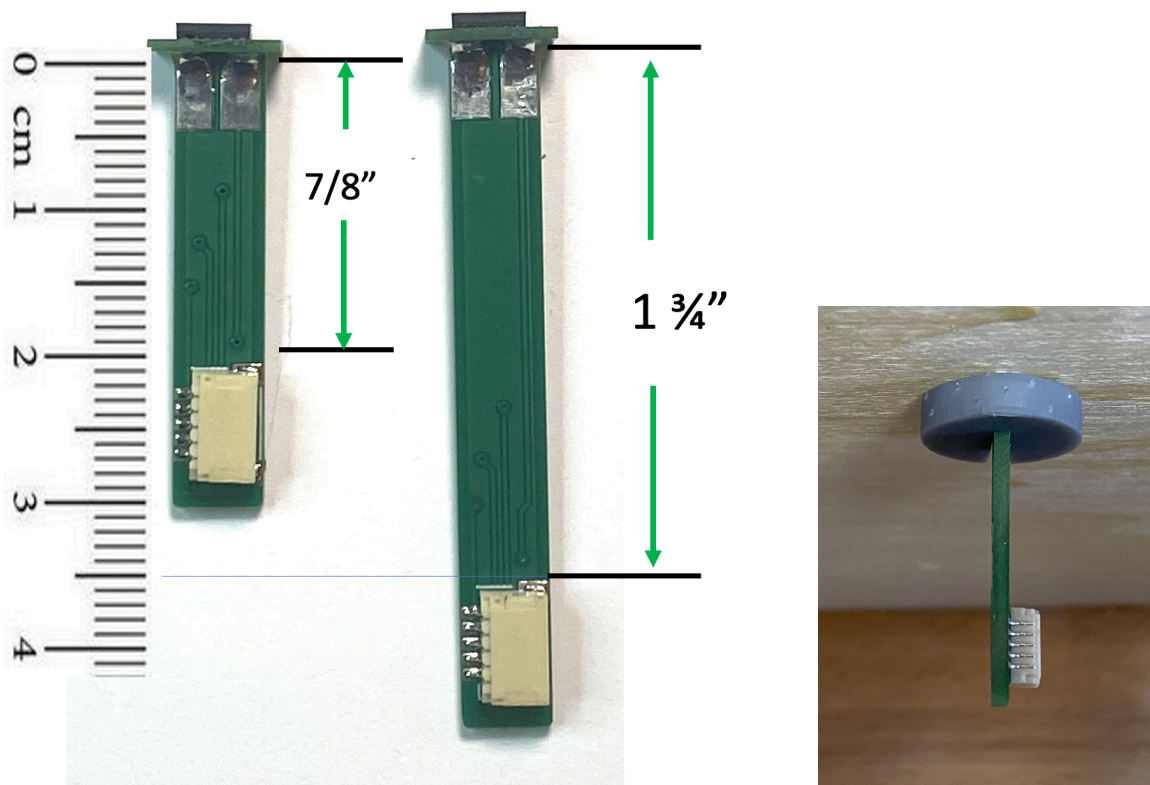

There are sizes: Short and Long. Use a 9/32" twist drill bit to drill a hole between the rails. We recommend you remove at least one of the ties so that you are drilling through the underlayment or roadbed and not through the plastic rails.

A friction nut can be used to hold the sensor in place. It slides on and off the vertical post.

The Slide-Under sensor comes in two sizes: HO and N scale.

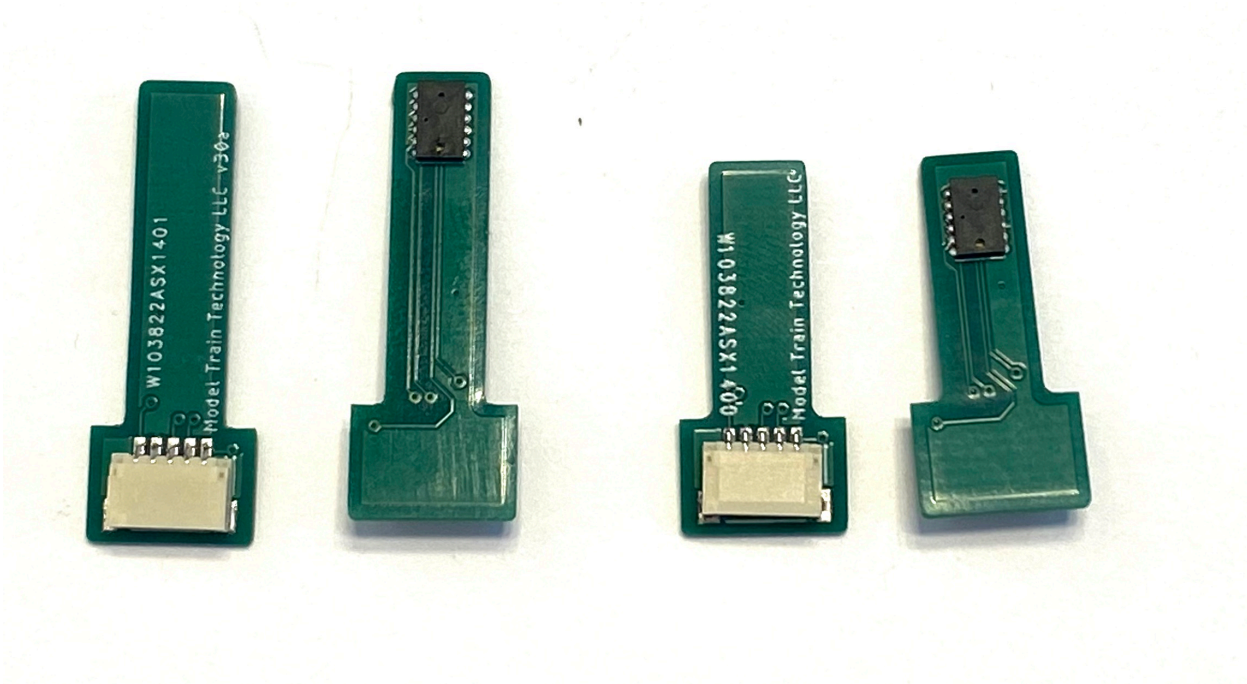

A small 3D printed electrical box can be used to cover the plug and wires. A 9/32" hole is required to fit the plug and cable through the layout surface.

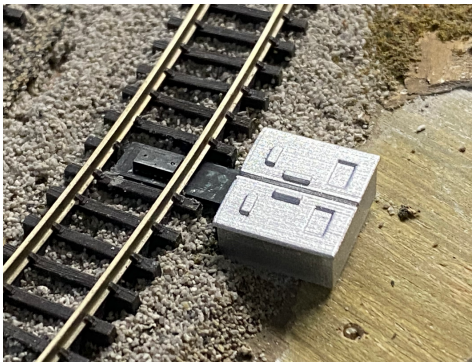

INSTALLATION SUMMARY

Plug the Sensor cable into the Nano Controller on the right side FIRST. This cable is a 5-Pin connector. This plug will NOT fit on the left side 4-pin socket. In this way you cannot make a mistake. The plug will fit only one way – smooth side up.

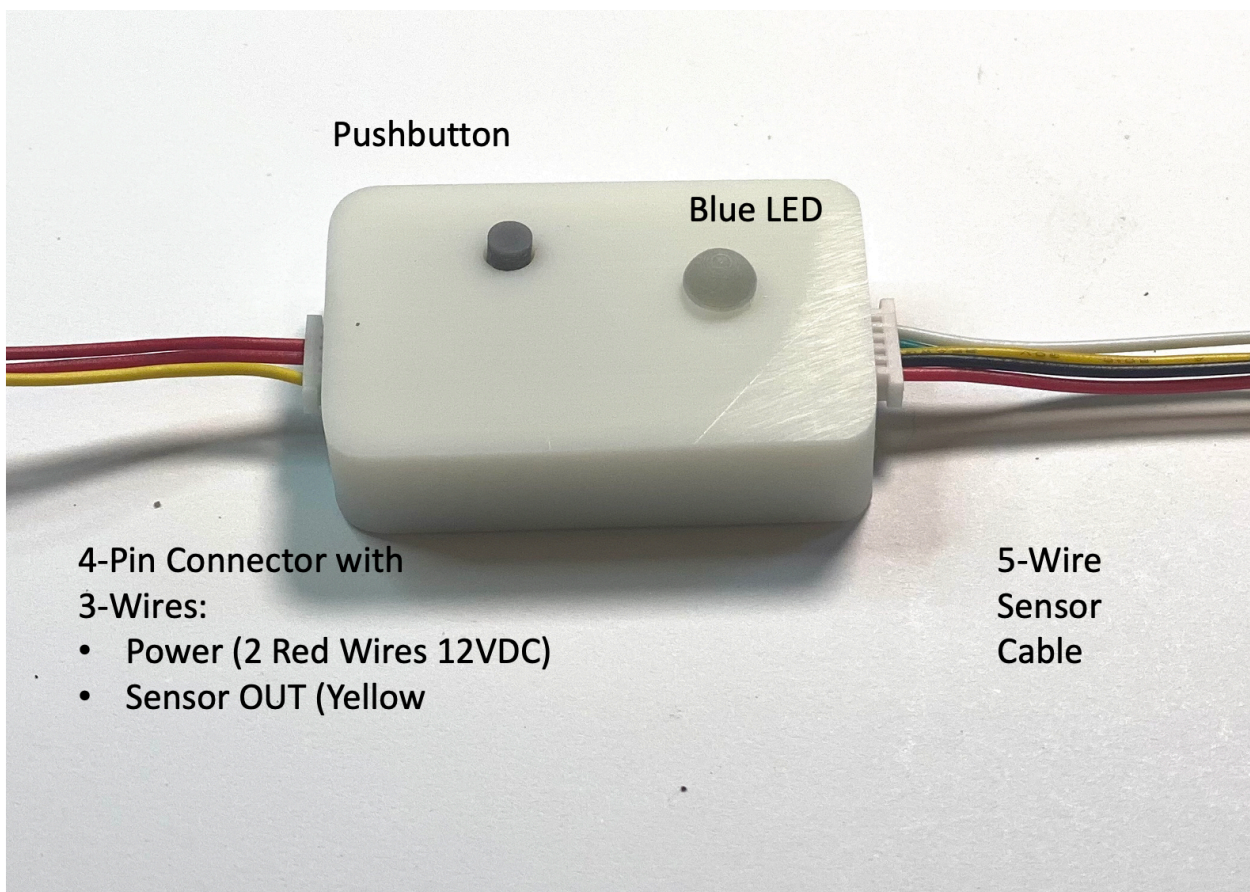

Plug the sensor into the 5-wire connector BEFORE turning the power on – otherwise it will not start or calibrate.

The Model Train Technology™ **PRECISION DETECTOR™ – NANO** is designed to provide an adjustable, multifaceted, and *precise* way to detect trains with the least amount of work to install and operate. At last, there is no need to adjust or calibrate for changing or difficult light conditions. The NANO sensor is small enough to fit between the rails of N Scale track (or any scale larger) and is tethered by a five-wire harness that connects to the “brains” controller that you place under the layout.

After we had our share of frustration with IR (infrared) detectors that use reflected light and are susceptible to changes ambient light, particularly florescent, some LEDs and mercury bulbs found at large train shows, we searched for a smaller, faster, more precise technology that would also be impervious to poor light conditions. The sensor we chose, along with our software, will detect without regard to lighting conditions.



Summary of Features:

- 3 pre-set sensor distances for N, HO & O
- Precise sensor range (1mm up to 150mm)
- No more adjusting for varying light conditions.
- Auto-calibration mode for precise range setting
- Short range under track mean no false tripping
- Adjustable time-out (0-60 seconds)
- Reversible Signal output (INVERT)
- One Shot mode
- Includes a 2mm screwdriver.

The board should be powered with a 12VDC supply which is what the MTT Power Module outputs. To make sure all the detection works properly we designed a low-cost Power Center Module that comes with a power supply.

To operate properly the Signal Controller or MTT Relay and the NANO Precision Detector must be connected to the same power source.

On the board is a blue indicator LED. This will flash four times when power is first turned on and thereafter will light when the detector is triggered. (INVERT mode will have the light ON when not triggered and OFF when triggered)

NOTE: If the Blue LED doesn't not Flash four times rapidly at power on, no amount of pressing the select button will help. Either the cables are not connected properly, a pin is bend or the unit is faulty. If the LED blinks continuously about 2 times a second then the sensor is not connect or has a fault.

SENSOR HANDLING

The Sensor has three tiny openings that measure the distance to an object. From our testing we found these to be reasonably tolerant of dust that invariably will collect. Use a SOFT paint or makeup brush to gently whisk away dust that collects.

Cover the sensor gently with a bit of blue painters' tape anytime you are using glues or spays in the vicinity.

For setup, press the SELECT button according to this chart:

The wires of the sensor are slightly twisted. You can reduce the twist but do not "tighten" the twist.

The wire length is about 9". This is the MAX length where the sensor will work properly. The signal in the wire is relatively low power (weak) so it can be upset by electrical noise from nearby wires. Try to keep the sensor wires away from other wires and do not cross over wires is possible.

Immediate mode (No Timeout) is very fast and it available for you to use. However, we strongly recommend you set the timeout to 5 seconds (#6) to avoid "signal collision". Setting the value to a 5 second timeout makes the NANO extremely reliable.

All you do is push the SELECT button to fit your scale and adjust the location of the sensor to meet your specific needs.

NANO PRECISION DETECTOR SETTINGS

1	N Scale (20mm) Range
2	HO Scale (30mm) Range
3	O Scale (50mm) Range
4	No Timeout
5	INVERT mode
6	5 Second Timeout
7	10 Second Timeout
8	15 Second Timeout
9	30 Second Timeout
10	45 Second Timeout
11	60 Second Timeout
12	One Shot Toggle On/Off
13	RESET to Factory Defaults

The detector can be also set to detect an adjustable **Long Range** from 5mm up to 150mm. In this case, the sensor does not have to be mounted under the track. You can use it anywhere. Anything within the range you set beginning at 5mm - will trigger the detector.

To use the **LONG RANGE** you will use the Auto-Calibrate mode that you may be familiar with in our other Precision Detectors.

AUTO-CALIBRATE for LONG RANGE

1. Press and hold the select button on the sensor. The blue light will turn on momentarily and then go off. KEEP holding until the light comes back on.
2. When the light comes back on, RELEASE the button.
3. The LED will blink slowly 5 times, once per second, to allow you time place a train car on the track in front of the sensor you wish to calibrate.
4. After 10 seconds (5 blinks) there will be a 1 second pause and then the LED will blink very rapidly for about 1 second. This rapid blinking is when the sensor Auto Calibrates (measures) the detected train car distance. That distance is saved in the memory of the sensor.
5. After the rapid flashing the sensor LED will go out for 2 seconds and then return to normal operating mode. The LED should go back on since it now detects the rail car on the track in front of it. Move the rail car and the LED should go out.

NOTE: It is BEST to set the timeout adjustment to zero so that the LED will go out immediately after you move the rail car. This makes confirming the correct operations much easier.

If you are using the **PRECISION DETECTOR™** with our MTT Signal Controller or MTT Relays you will most likely want to leave the setting to 5 seconds and let the Signal Controller manage the signal light timing. If you are using our Sound Module, then use the **PRECISION DETECTOR™** timing to adjust when to stop a sound after the train has passed. An example would be a crossing bell sound. With our Fiber Lighting Controller and a gate crossing use the **PRECISION DETECTOR™** to set the timeout so the lights and sound stop at the same time.

The **PRECISION DETECTOR™** provides a DIGITAL signal output (LOW) which is the kind used by many model railroad electronic controls that you would normally hook up such as sound modules, Light Controllers (like our Fiber and LED Controllers) and Block Signal Controllers. This detector can be configured to switch a relay that has a digital input option, but it cannot power or switch the relay itself.

INSTALLATION and TESTING

Connect the RED power wires to your 12VDC power source. There is no polarity required. With power ON you can place your hand in front of the sensor and the blue LED should light and go off when you move away.

The Yellow Signal (SIGNAL) wire can now be connected to the controller device of your choice. The signal protocol is called OPEN DRAIN (LOW). This simply means that the device will work with control units that are looking for a connection to GROUND through the signal wire.

HOWEVER, the detector must have a way to connect back to a source of ground. The most bullet proof way to do that is to have the controlling device and the detector powered by the same power supply. Then naturally they will share a common ground through the power supply, and everything will work fine.

INVERTED SIGNAL

An INVERTED SIGNAL simply means that the **NANO PRECISION DETECTOR™** will send an ON signal when the sensor is OFF, and visa versa. You can tell this is the case if the blue LED is always on but turns OFF when you place your hand in front of the sensor. Why would you use this? You can use this when you are connection to a block signal system or more likely if you are using our MTT Sound Module. You can have ambient background noises going while the train is away and then have them turn off as the train (with sound) passes or pulls into the station. To change the Signal out to INVERT, change the right most DIP switch to ON (up position).

ONE SHOT MODE

When set to One Shot Mode, the sensor will activate as usual but then will release the Signal after a set time even if the sensor is still covered by a train. That release time could be immediately (100ms), or it can be any of the timeout times listed in the detector setting chart. Only when the sensor is cleared will the circuit reset to await another activation. This is very useful when combined with our two Relays (Standard and Latching) to create animated train motions.

ELECTRONICS AND STATIC ELECTRICITY

The ***MTT PRECISION DETECTOR™ - Trackside*** circuit board and components are exposed when the cover is off. Static electricity can cause component failure. Scuffing along a carpet and then touching one of the component connectors can cause a static spark. These components are fairly rugged – some designed for the automotive industry. Just be mindful of the risk. The current on the board will not harm you if the board is powered as per the instructions.

ONE YEAR MANUFACTURER WARRANTY: We warrants this **product** to be free from defects in workmanship and materials, under normal residential use and conditions, for a period of one (1) year for the original invoice date. Shipping and handling fees are to be paid for by the customer.

LIMITATION OF LIABILITY

UNDER NO CIRCUMSTANCE SHALL COMPANY OR ITS AFFILIATES, PARTNERS, SUPPLIERS OR LICENSORS BE LIABLE FOR ANY INDIRECT, INCIDENTAL, CONSEQUENTIAL, SPECIAL OR EXEMPLARY DAMAGES ARISING OUT OF OR IN CONNECTION WITH YOUR USE, OR INABILITY TO USE THE PRODUCT, WHETHER OR NOT THE DAMAGES WERE FORESEEABLE AND WHETHER OR NOT COMPANY WAS ADVISED OF THE POSSIBILITY OF SUCH DAMAGES. WITHOUT LIMITING THE GENERALITY OF THE FOREGOING, COMPANY'S AGGREGATE LIABILITY TO YOU SHALL NOT EXCEED THE AMOUNT OF THE PRODUCT. THE FOREGOING LIMITATION WILL APPLY EVEN IF THE ABOVE STATED REMEDY FAILS OF ITS ESSENTIAL PURPOSE.



Model Train Technology LLC

10524 Moss park Rd. Ste. 204-256

Orlando, Florida 32832

407-242-5436

www.ModelTrainTechnology.com

support@modeltraintechology.com

Version 2.0b

Copyright© 2023 Model Train Technology LLC